

K40 PLUS

The first energy efficiency
class A minibar



SAVE MONEY WHEN PURCHASING

- Minibar could be expensive in terms of energy consumption.
- They are switched “ON” 24 hours a day and all year long.
- The quantity of energy consumption taken by minibar could reach the 10% of a hotel’s total energy costs.
- The minibar’s capacity to cool (cooling time) does not depend on energy consumption.

The cooling capacity/efficiency depends on the type of cooling system used to produce the minibar.

There three different cooling system are used in minibars:

- **Compressor** – with low energy consumption – with little more noise but with good cooling performance
- **Thermoelectric** – with considerable energy consumption – quite an good cooling performance
- **Absorption** – with high energy consumption – quite but reduced cooling performance

An independent test laboratory has been requested by an Hotel Association to run some test on minibars available on the market to identify the low energy minibar and the most efficient.

Low energy consumption is considered when less than 0.55 kWh/24h.

High energy consumption is considered when higher than 1,25 kWh/24h

Between minibars tested it is very interesting to compare the following two best sellers minibars produced by Dometic and Indel B

brand	cooling system	energy consumption kWh/24h	net volume liters	energy label	cooling performance	noise dB
Indel B K40ENT	compressor	0,45	31	B	5h 09 min	39
Dometic Hipro 4000	absorption	0,78	33	F	5h 35 min	27

At the present there is no compulsory energy labelling for minibars.

From test result it is very interesting to see how big could be the difference in terms of energy consumption as well as in energy savings.

Minibars have been tested according to EN153 (ISO7371)

Both standards specify that test ambient temperature should be 25°C and inside temperature +5°C. (These information are not always clearly printed)



from class B to

A

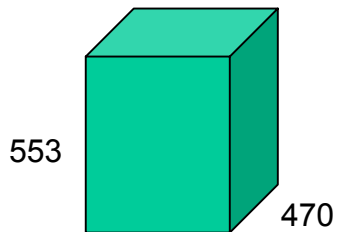

Inner door will change its design in the near future. See drawings on next pages



The design

The compressor cooling unit is covered allowing a free standing installation

Large flat evaporator and the eutectic plate

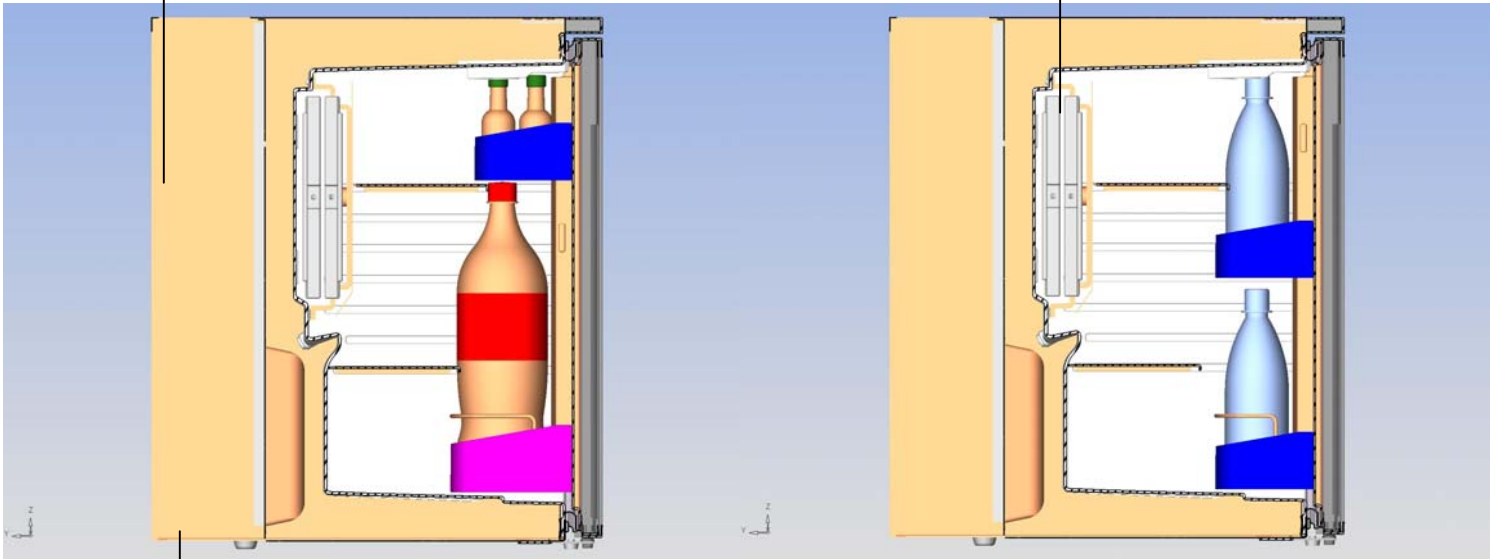

Extremely high insulation to minimize energy consumption

Various inside door configurations to meet all needs

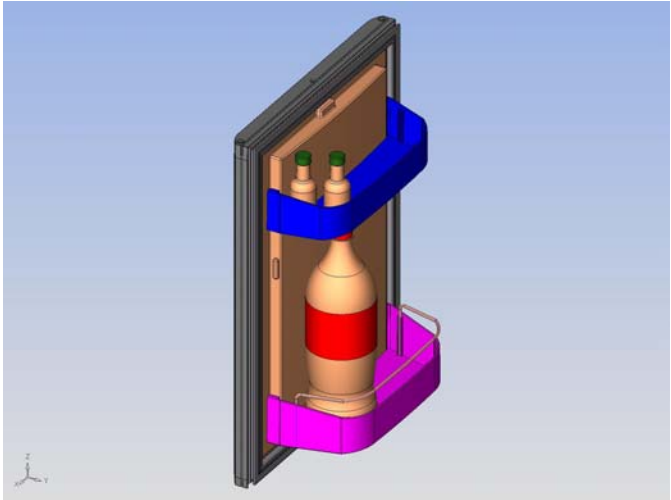
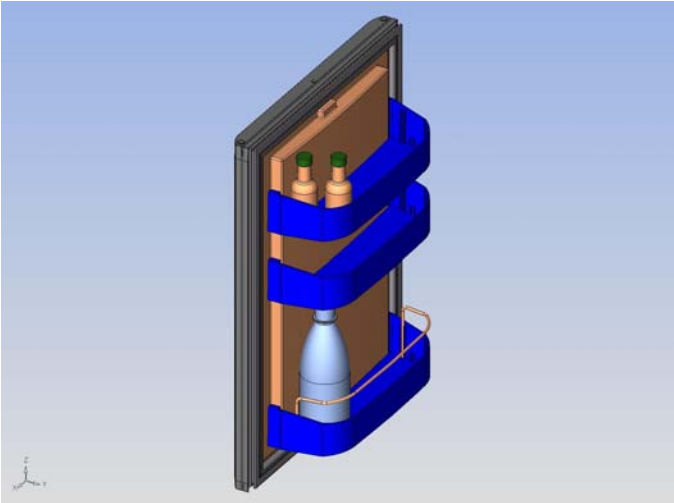
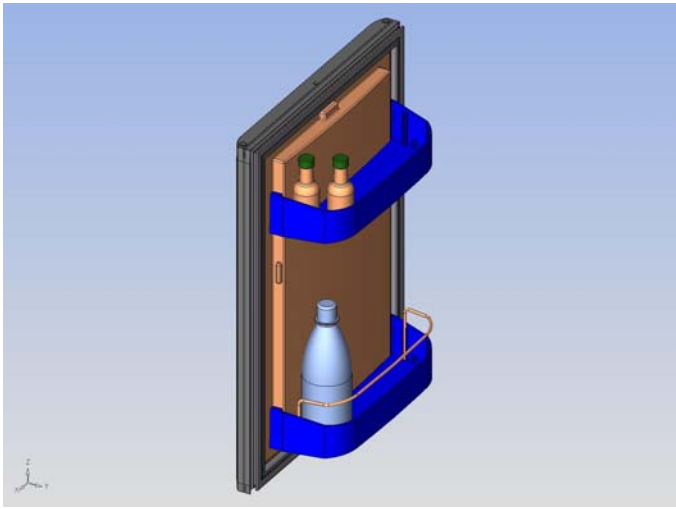
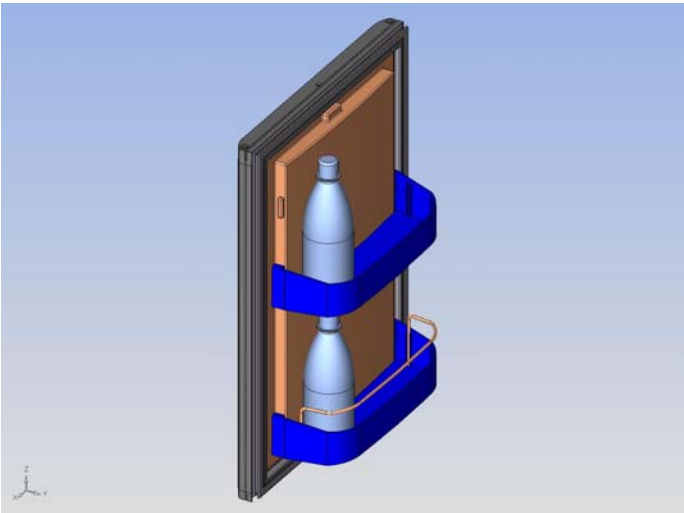

The first class **A** minibar



Energie	
Hersteller	
Modell	
Niedriger Verbrauch	
A	
B	
C	
D	
E	
F	
G	
Hoher Verbrauch	
Energieverbrauch kWh/Jahr (Auf der Grundlage von Ergebnissen der Normprüfung über 24 h)	314
Der tatsächliche Verbrauch hängt von der Nutzung und vom Standort des Geräts ab.	
Nutzzinhalte Kühlteil I	205
Nutzzinhalte Gefrierfach I	70
Geräusch	
dB(A) re 1 pW	
Ein Datenblatt mit weiteren Geräteangaben ist in den Prospekten enthalten.	
Norm EN 153, Ausgabe 1990 Kühlerste-Fischlinie 94/2/EG	

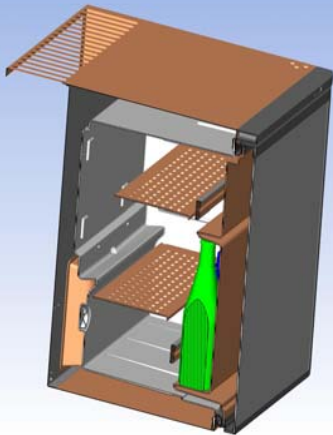

•The extremely thick insulation will reduce to the minimum the energy consumption

•It is our aim to offer for the first time a minibar with an efficiency class A

About energy consumption



Refreshment Center Solutions

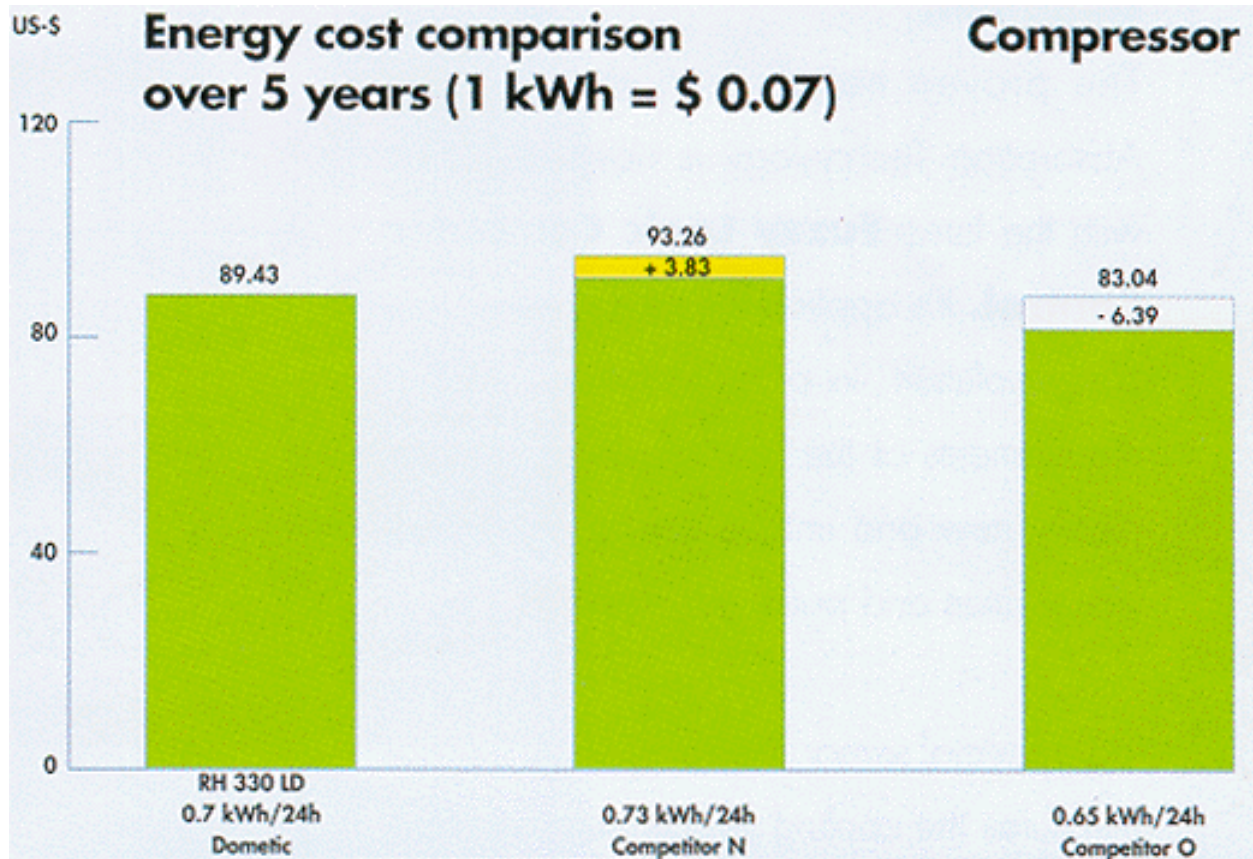

K40Plus

38,32

- 51,11

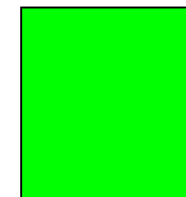

0,3 kWh/24h

Indel B

Minibars are tested at 25°C

(the above graph is published on the Dometic website)

How a compressor minibar could be silent and still very efficient

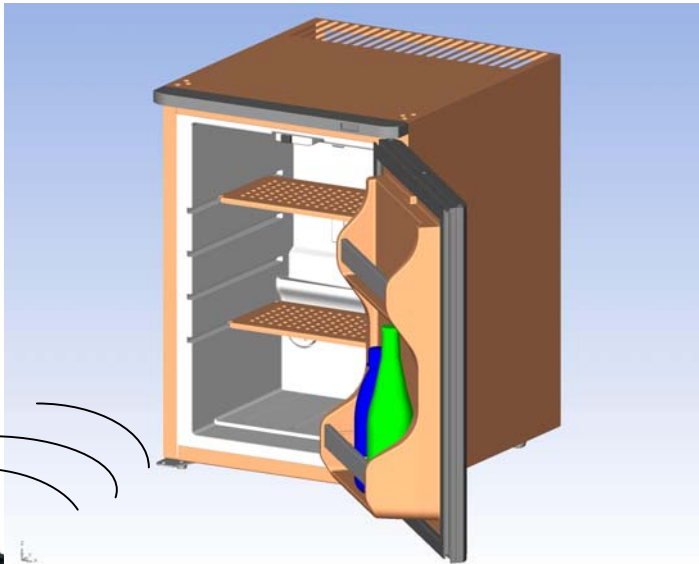

The remote control sets the inside timer and the working/rest time of compressor. The remote control offers also the possibility to put minibar OFF (WHEN rooms are not used for long periods, for example seasonal hotels)

Each minibar has an electronic timer and an eutectic plate that has the property to store a great quantity of cold in a short time and to release it over a long time

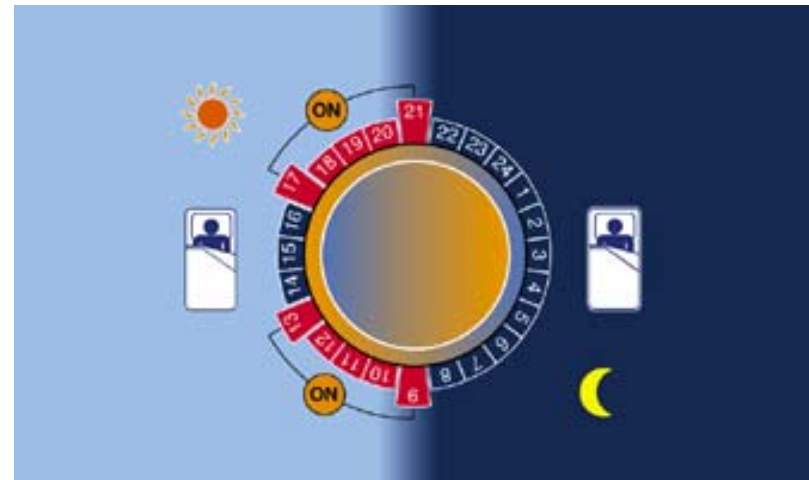

**K40 PLUS - COMPRESSOR MINIBAR WITH EUTECTIC PLATE AND TIMER
 PRELIMINARY TEMPERATURE TEST - AMBIENT TEMPERATURE 25°C
 TIMER SETS TO OPERATE COMPRESSOR 6 HOURS PER DAY**

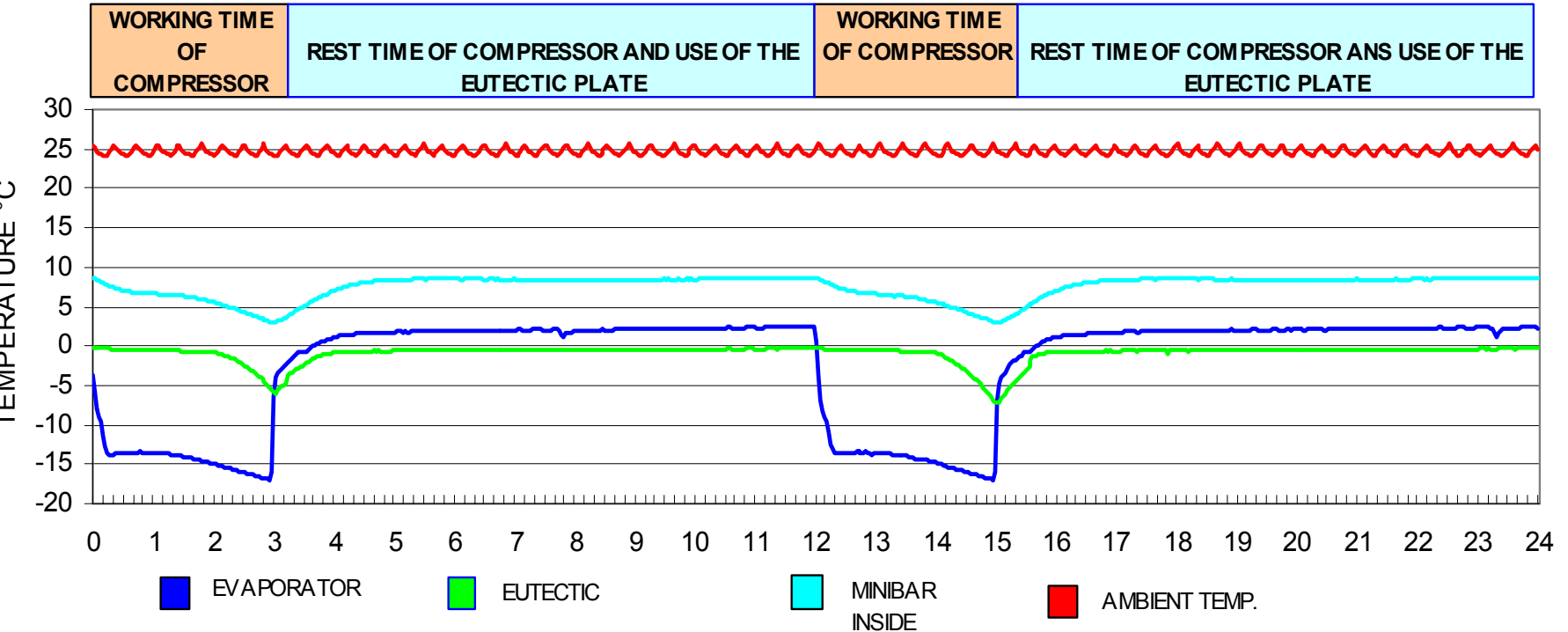

The energy consumption recorded during our internal test and now confirmed by the test laboratory shows a daily consumption of:

0,3 kWh/24h

During the operating time of compressor the inside temperature is constantly under 5°C while during the rest time of compressor the inside temperature remains between 5 and 8°C.

All components are in accordance to safety and environment regulations.

We have minibars K40PLUS under test by a qualified and independent laboratory. Copy of these tests results will be sent you as soon as available.



We are ready to meet your requirements.

Contact us:

INDEL B SpA

Loc. Ca' Baldone

61019 Sant'Agata Feltria –PU - Italy

Phone + 39 - 0541 – 848711

Fax + 39 – 0541 – 848000

E-mail indelb@indelb.it

marketing@indelb.it

www.indelb.com